

S-RF0018 Radial Tape Feeder operation manual

Thanks for order this feeder from us , please read this manual carefully before operation

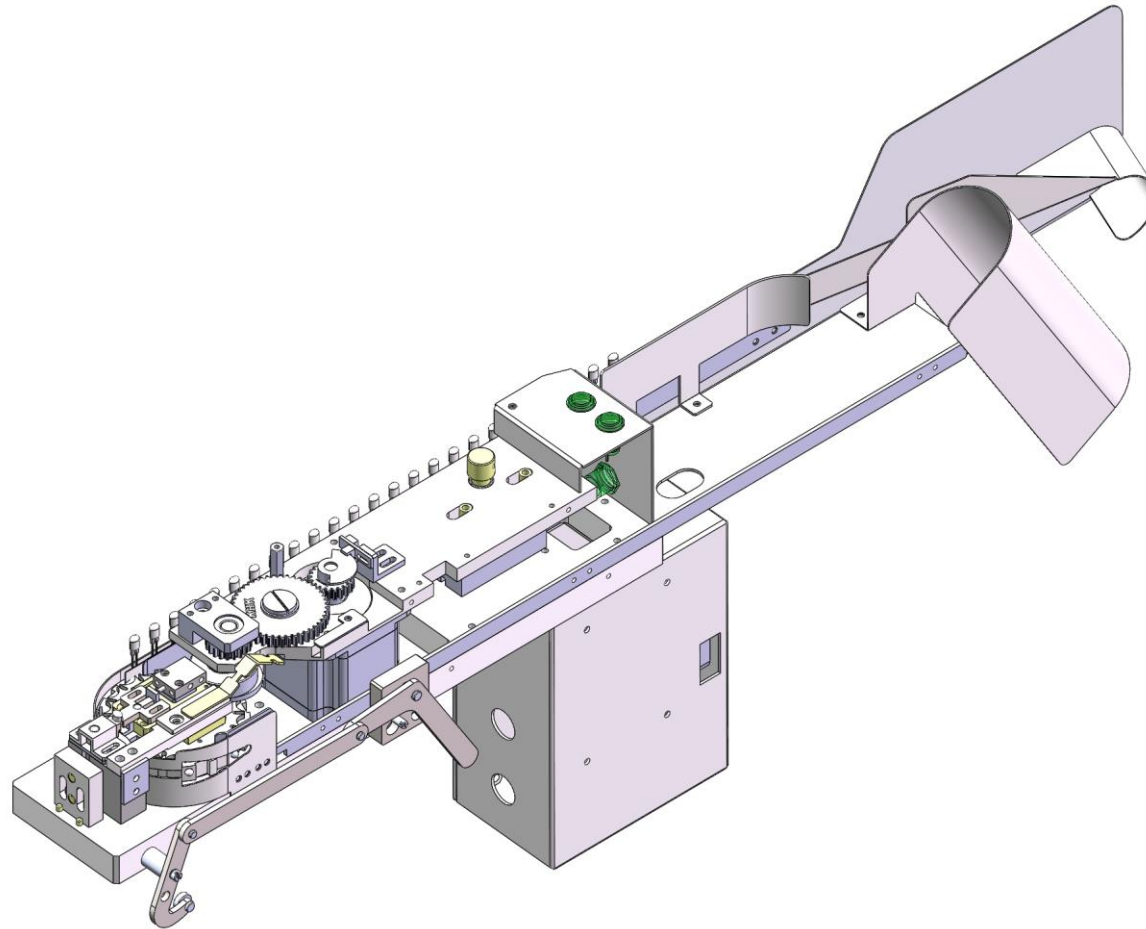

1. Wiring

Please connect black wire with tag 0V to machine power Supply 0V.

Please connect red wire with tag 24V to machine power Supply 24V and feeder drive signal 24V.

Please connect black wire with tag X1 to feeder drive signal 0V.

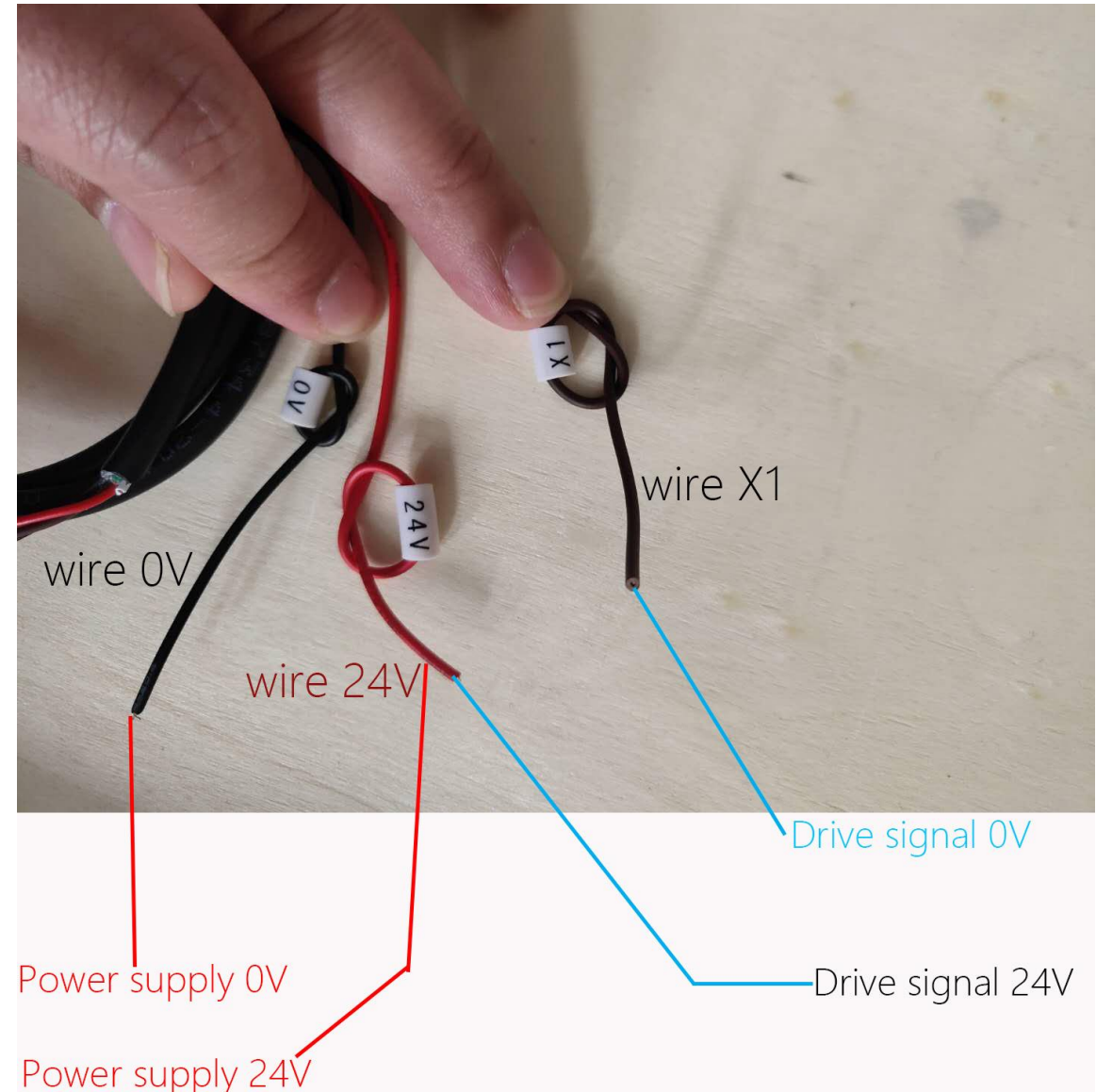

2. LED loading and unloading

Please refer to below video link for loading and unloading guideline.

Loading : https://youtu.be/II_DMunRQjo

Unloading: <https://youtu.be/Ovym4PsZ3uM>

3. Operation

Red mark 4: Power button

Red mark 3: Feeding button

Red mark 2: Reset button
(all mechanical device return to origin)

Red mark 1: Motor Pin , with insert / pull out this Pin , we can connect / disconnect between “motor ASSY(green below)” and “driven gear ASSY(red below)” by move the whole motor ASSY by hand

While loading/unloading LED tape , we suggest pull out the pin to disconnect motor and driven gear, to make driven gear free to rotate.

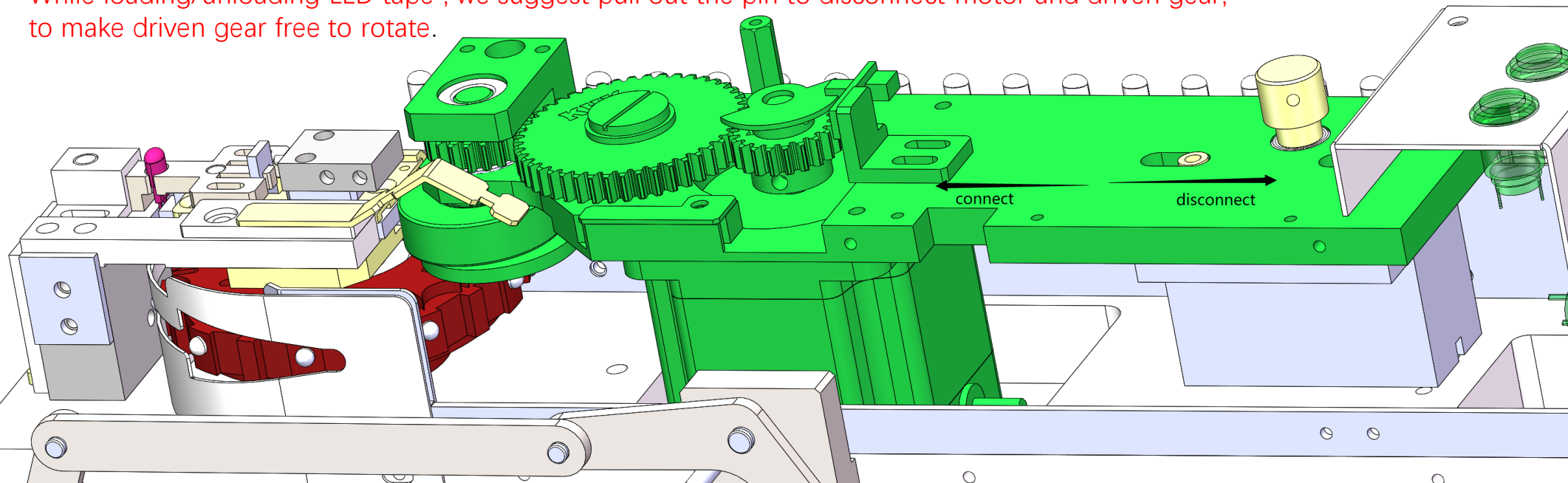
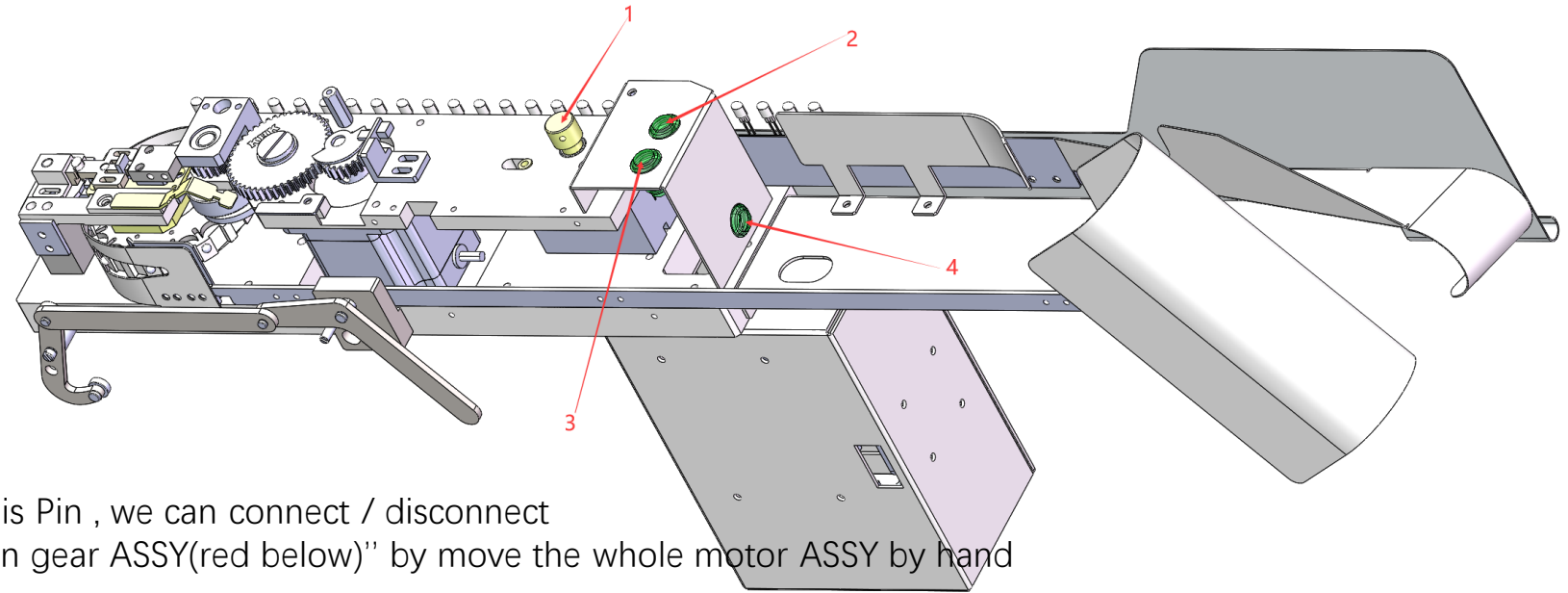

4. Adjustment

We can adjust the position of clamp1 for make LED being Tighter or looser , by open screw 1&2.

We can adjust the position of clamp2 for make LED being Stronger or weaker spring support ,by open screw 3&4.

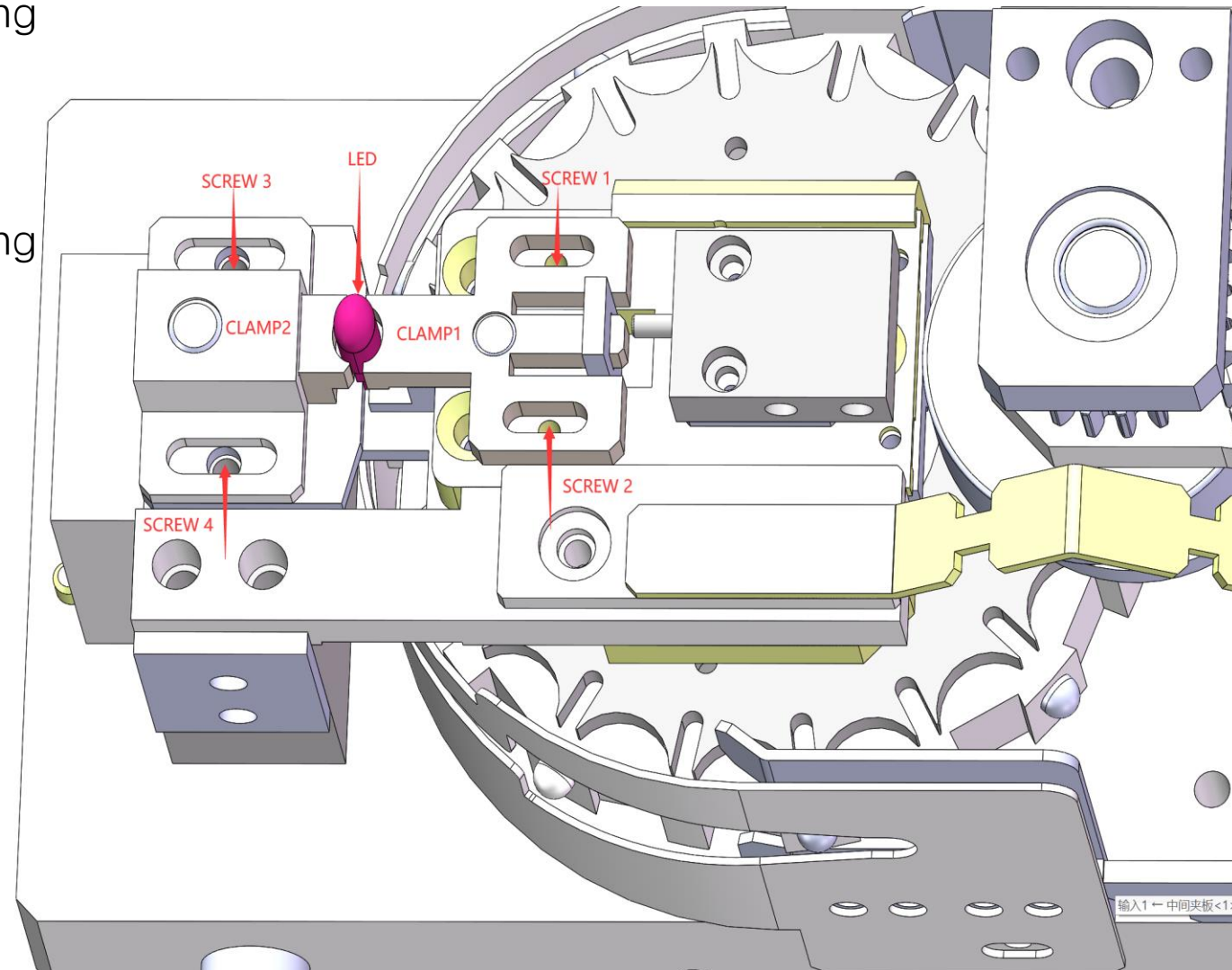

Thanks

More information, please email to albert@smthelp.com.